

Product Specification:

MONA

Dressing and Changing Table



Highlights:

- Height adjustable scissor frame
- Easy to clean padded bench top
- Smooth, braked casters
- Floor and ceiling hoist access
- Optional guards and bumpers

The Mona Dressing and Changing Table is designed to maximise comfort and ease of use for care givers. The sturdy scissor frame height adjustment is operated by either a handset (electric mains and rechargeable battery models) or foot pedal (hydraulic models), which allows the carer to gently raise the bed to a comfortable height for dressing and changing.

The easy to clean thick padded surface area is made from an extremely robust imitation leather Skai® vinyl material, which is often used in medical practices and provides a comfortable area for dress and treatment. It also has a number of additional options including tilting backrest, fold up guards and protective padded bumpers to ensure enhanced comfort.

As with all Astor-Bannerman products, the Mona mobile changing bench is manufactured from top quality materials, giving our customers peace of mind that their new equipment is built to last. It has been the changing table of choice for many high profile clients.

The Mona has smooth, braked casters allowing it to be easily manoeuvred, and has generous space underneath for mobile hoists to be easily positioned alongside.

The Mona comes in a range of sizes from 1500mm x 650mm up to 1950 x 1000mm with a safe working load of 150kg (electric) and 135kg (hydraulic). It is also available in a wide range of colours to complement individual room designs and/or client preferences.



STANDARD FEATURES

- SWL 150kg/23½st (hydraulic), 135kg/21¼st (Electric)
- Height range 490mm - 955mm (hyd), 4465m - 1005mm (elec)
- Height adjustable (mains electric, battery or hydraulic)
- Handset operation
- Floor and ceiling hoist access
- Comfortable integrated padded top
- Smooth adjustment
- 3 Year warranty (Terms and conditions apply)



OPTIONAL EXTRAS

- Sizes from 1500-1950 x 650-1000mm
- Electric mains, battery or hydraulic operation
- Fold away safety side guards
- Fold away safety end guards
- Protective padded guard bumpers
- Tilting head/backrest
- Fixed padded top
- Wide range of colours available
- Special fully coloured models available
- Range of service & maintenance packages
- Please call 01242 820820 for more information

MONA

Dressing and Changing Table

Product Specification:

Model: Mona Mobile Dressing and Changing Table

Product Code/s: 02.120.00.1565/1580/1951/1958 (Hyd) - 1500x650/1500x800/1950x1000/1950x800
02.120.01.1565/1580/1951/1958 (Elec) - 1500x650/1500x800/1950x1000/1950x800

Stretcher Size: 1500mm (L) x 650mm (W) / 1500mm (L) x 800mm (W)

Height Range: Hydraulic: 490mm - 955mm (465mm) / Electric: 465mm - 1005mm (540mm)

Features:

| | | | | |
|--------|------------------------------------|----------------------------------|---------------|------------------------------|
| | SWL 150kg (hydraulic) | SWL 135kg (battery) | | 3 Year Warranty |
| Height | 150kg/23½st | 135kg/21½st | Ceiling/floor | 3 Year |

Options:

| | | | | | | | |
|---------------|--------|-----------------------------|-----------|---------------|------------|---------|-----------|
| | | 1500x650 to 1950x1000 | | | | | |
| Mains/Battery | Manual | Range of | Fold Away | Tilting Head/ | Wide range | Service | Many More |

Dependency Level: High
Dependency

Application:

| | | | | | | | |
|--------------|--------|----------------|-----------|--------------|--------------|----------|-----------------|
| Private Home | School | Leisure Centre | Care Home | Nursing Home | Respite Home | Hospital | Changing Places |
|--------------|--------|----------------|-----------|--------------|--------------|----------|-----------------|

Technical Drawing:

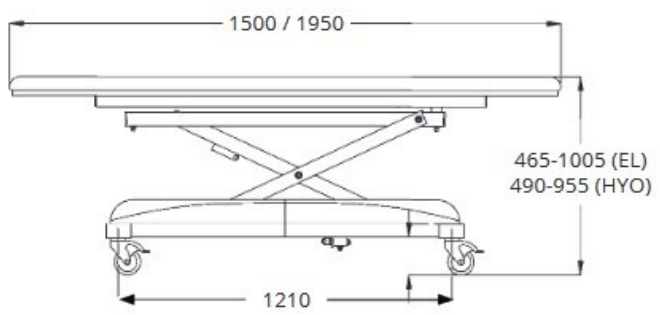

1500mm Model:

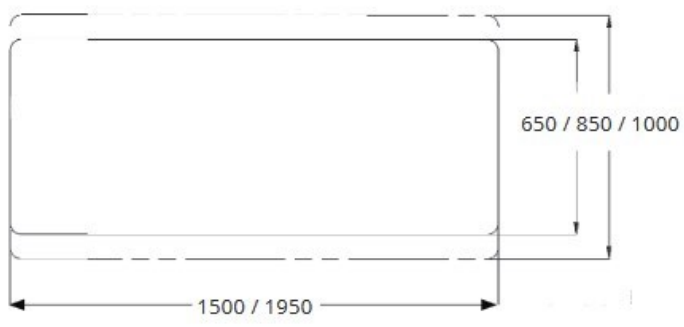
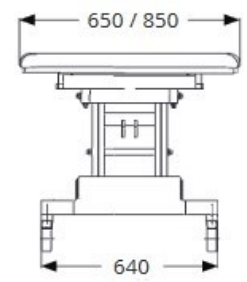

1950mm Model:

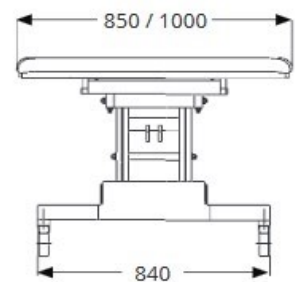

Astor-Bannerman Unit 11F Coln Park, Andoversford, Cheltenham, Gloucestershire, GL54 4HJ
 sales@astorbannerman.co.uk 01242 820820 www.astorbannerman.co.uk