

Product Specification:

Multicare XXL

Showering and Changing Trolley



Highlights:

- Bariatric capacity up to 265kg
- Trendelenburg and reverse Trendelenburg tilt feature
- Eight double castors (4 lockable) for independent suspension
- Flexible convenient waste pipe
- Fold away guards and mattress extension

The mobile **Multicare XXL shower, changing and treatment trolley** has a **capacity of up to 265kg and generous dimensions of 2040mm x 990mm, catering for bariatric care.** It is not only a great form of transportation, but also provides a safe, secure and waterproof platform for treatment and care. Its height can be adjusted by an electronic handset control or by a manual hydraulic foot pedal, as can its Trendelenburg positioning.

Dual rocking-castor suspension on the Multicare trolley gives a smooth ride, even over difficult surfaces, and can be locked to secure the trolley in a location.

The waterproof stretcher plate combined with powder coated stainless steel frame construction provides years more life than comparable mild steel trolleys - especially when used in wet or humid environments. The Multicare trolley also comes with 4 folding and self-locking guards, a 10mm laminated and waterproof platform, extendable head rail, drain hole with flexible waste pipe, and disinfectable PVC shower mat, making this an excellent option for us in all wet and dry environments.



STANDARD FEATURES

- SWL 265kg
- Height range 540mm - 865mm
- Height adjustable (electric or hydraulic)
- Eight double castors (4 lockable) for independent suspension
- Flexible waste pipe
- Removable and self locking head and foot rails
- Powder-coated stainless steel frame
- Trendelenburg and reverse Trendelenburg feature
- Extendable head rail for extra length
- Generous length: 2040mm
- 3 Year warranty (Terms and conditions apply)



OPTIONAL EXTRAS

- Electric battery or manual hydraulic operation
- Waterproof wedge shaped cushion
- Replacement rechargeable battery
- External charging station
- Range of service & warranty packages
Please ask for further details.

Product Specification:

Product Code/s: 02.121.00.1600 (1600mm Hyd) / 02.121.00.2000 (1900mm Hyd)

02.121.01.1600 (1600mm Elec) / 02.121.01.1950 (1900mm Elec)

Trolley Size/s: 1600mm (L) x 635mm (W)

Height Range: 540mm - 865mm (325mm)

Features:

Height	165kg/26st	Side and End	Ceiling/floor	Shower	3 Year

Options:

Battery	Manual	Range of 1600 or 1900	Waterproof	Service	Many More

Dependency Level:

High
Dependency

Application:

Private Home	School	Leisure Centre	Care Home	Nursing Home	Respite Home	Hospital	Changing Places
--------------	--------	----------------	-----------	--------------	--------------	----------	-----------------

Technical Drawing:

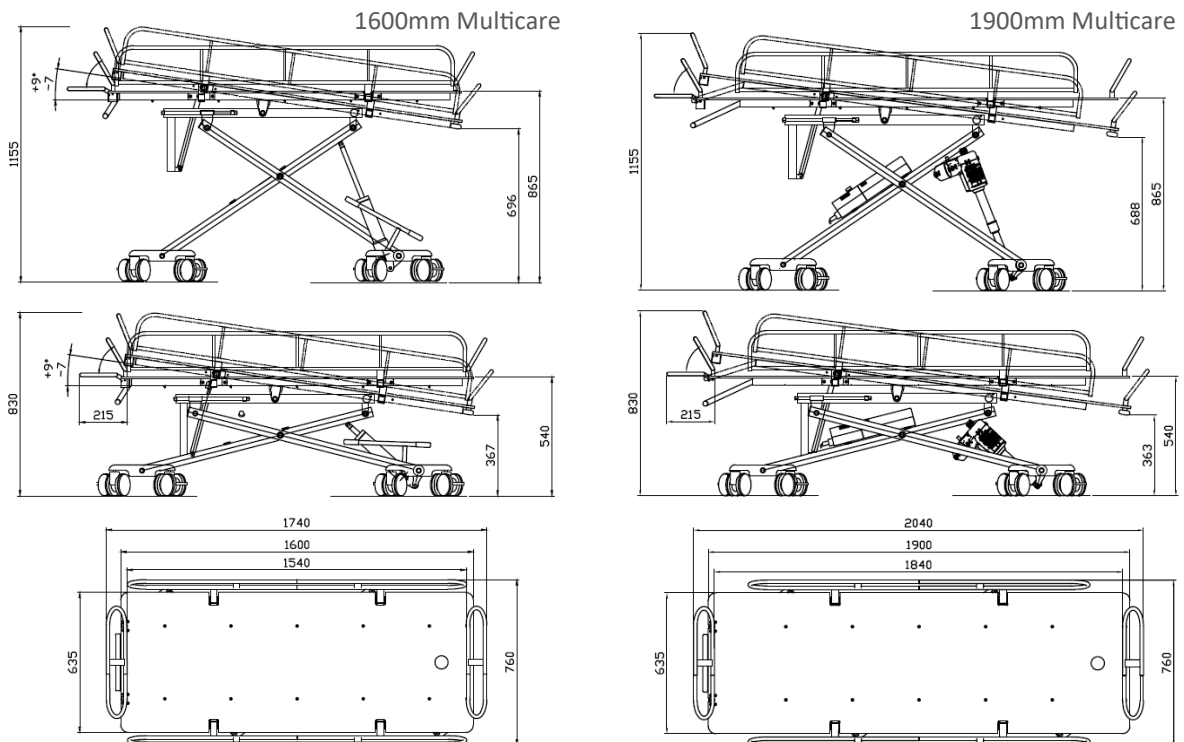

Astor- Bannerman Unit 11F Coln Park, Andoversford, Cheltenham, Gloucestershire, GL54 4HJ